

No. 644,748.

Patented Mar. 6, 1900.

C. A. SVENSSON.
SCREW TAP.

(Application filed July 27, 1899.)

(No Model.)

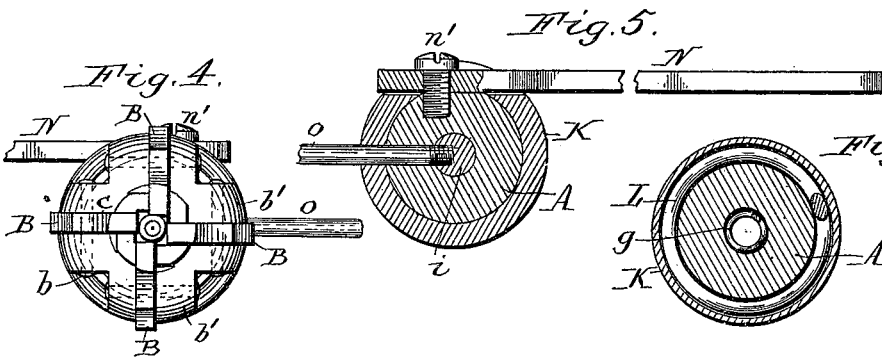
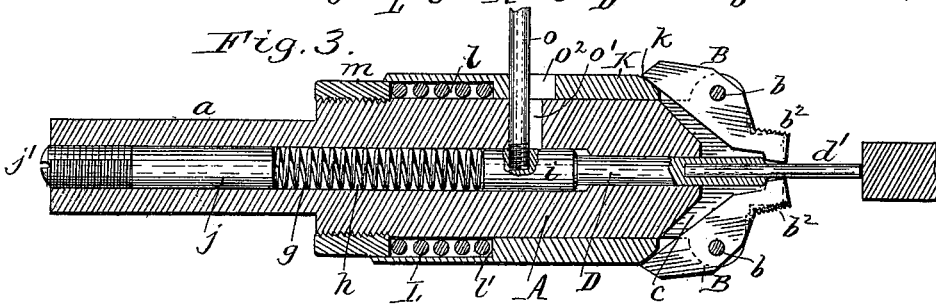
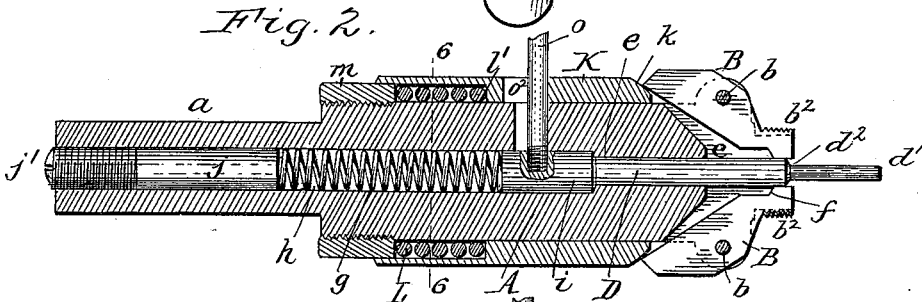
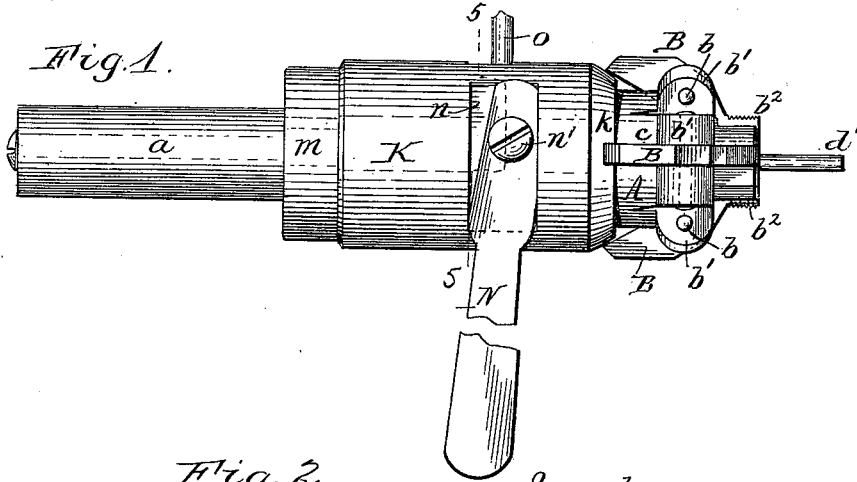

Witnesses:
 F. F. Schuzinger.
 E. A. Volk

C. A. Svensson Inventor.
 By Wilhelm Horned.
 Attorneys.

UNITED STATES PATENT OFFICE.

CLAES A. SVENSSON, OF BUFFALO, NEW YORK, ASSIGNOR OF ONE-HALF
TO WILLIAM W. OLIVER, OF SAME PLACE.

SCREW-TAP.

SPECIFICATION forming part of Letters Patent No. 644,748, dated March 6, 1900.

Application filed July 27, 1899. Serial No. 725,300. (No model.)

To all whom it may concern:

Be it known that I, CLAES A. SVENSSON, a citizen of the United States, residing at Buffalo, in the county of Erie and State of New York, have invented new and useful Improvements in Screw-Taps, of which the following is a specification.

This invention relates to screw-taps in which the externally-screw-threaded sections forming the tap are collapsible for facilitating the withdrawal of the tap from the work after cutting the screw-thread and preventing mutilation of the thread.

The object of my invention is to provide a tap of this kind which is simple and durable in construction and convenient in use and in which the tap-sections are automatically contracted as soon as the thread is cut.

In the accompanying drawings, Figure 1 is a top plan view of my improved tap, showing the tap-levers expanded to their operative position. Fig. 2 is a longitudinal sectional elevation thereof with the tap-levers in the same position. Fig. 3 is a similar section showing the levers collapsed. Fig. 4 is a front view of the tap. Fig. 5 is a cross-section in line 5 5, Fig. 1. Fig. 6 is a similar section in line 6 6, Fig. 2.

Like letters of reference refer to like parts in the several figures.

A is the stationary head or body of the tap, which is cylindrical in form and provided at its rear end with a reduced shank *a*, whereby it is secured in the turret of a lathe or other holder.

B represent tap-levers arranged lengthwise at the front end of the body A and pivoted by transverse pins *b* to bifurcated lugs *b'*, which project radially from the front portion of the body and are arranged equidistant around the latter, four of such levers being preferably employed, as shown in the drawings. The front arms of these levers are provided on their outer edges with screw-threads *b²*, which form the sections of the tap. The body is provided in its front end with longitudinal slots *c*, which receive the adjacent portions of the tap-levers. The rear portions of the levers extend outwardly beyond the surface of the body A, as shown.

D is an expanding rod or core arranged to

slide in an axial opening *e*, formed in the body A and adapted to engage between the inner edges of the front arms of the tap-levers for spreading the same and holding the taps or sections *b²* in their expanded position, as shown in Figs. 1 and 2. The front portion of this expanding-rod is reduced and extends beyond the front ends of the tap-levers to form a trip-rod *d'*. The expanding-rod is provided at its junction with this trip-rod with a conical shoulder or cam-face *d²*, which is adapted to bear against correspondingly-beveled faces *f*, formed on the inner edges of the tap-levers in front of their pivots. The expanding-rod is constantly urged forwardly by a spring *g*, arranged in an enlargement *h* of the axial opening *e* and bearing at its front end against a head or enlargement *i*, formed at the rear end of the expanding-rod, and at its rear end against a loose filling-piece *j*, which in turn abuts against an adjustable screw-plug *j'*. This screw-plug engages with an internal screw-thread formed in the rear portion of the axial opening *h* and is accessible at the rear end of the shank *a* for turning the same to properly regulate the tension of the spring *g*.

K is a sliding sleeve applied to the cylindrical body A and serving to contract or collapse the front arms of the tap-levers when the expanding-rod D is retracted. This contracting-sleeve is provided at its front end with a beveled or tapering face *k*, which bears against the inner edges of the tap-levers on the rear sides of their pivots, so that when the sleeve is shifted forwardly its beveled front end spreads or swings the rear arms of the tap-levers outwardly, thereby swinging the screw-threaded front arms of the levers inwardly and collapsing the tap, as shown in Fig. 3.

L is a spring which tends to shift the contracting-sleeve forwardly. This spring is preferably arranged in an annular recess *l*, formed by enlarging the rear portion of the bore of the sleeve, and bears at its front end against the internal shoulder *l'* of the sleeve and at its rear end against a stationary collar *m* applied to the rear end of the body A. The rear portion of the sliding sleeve overlaps this collar, as shown.

N is a hand-lever whereby the contracting-sleeve K is drawn backwardly for releasing the contracted tap-levers and allowing the expanding-rod D to spread the same preparatory to cutting the next screw-thread. The inner portion of this hand-lever is arranged in a transverse slot *n*, formed in the upper side of the sleeve and mounted on a screw or pivot pin *n'*, secured in the body A, as shown in Fig. 5. In shifting the sleeve the rear side of the hand-lever bears against the rear wall of the slot *n*.

In the use of my improved tap the front arms of the tap-levers B are expanded to their operative position by shifting the contracting-sleeve rearwardly to the position shown in Fig. 2, so as to allow the spring *g* to project the expanding-rod D and cause the same to enter between the inner edges of the opposing front arms of the tap-levers, the beveled shoulder *d*² of the advancing expanding-rod bearing against the beveled faces *f* of the tap-levers and spreading the same to the position shown in Fig. 2. In this position of the parts the expanding-rod serves as a core which resists the inward movement of the front arms of the tap-levers, causing the same to act like the screw-threaded portions of a solid or rigid tap. As the rear arms of the tap-levers bear against the front end of the contracting-sleeve they resist the forward movement of the same, keeping its spring L under compression. When the tap has cut a screw-thread of the desired length in the article to be tapped, the trip-rod *d'* comes in contact with the end of the lathe-spindle and forces the expanding-rod inwardly against the pressure of its spring *g*, thereby withdrawing the expanding-rod from between the front arms of the tap-levers. As soon as this occurs the sleeve K is shifted forwardly by the reaction of its compressed spring L, causing the beveled front end of the sleeve to swing the rear ends of the tap-levers outwardly, thereby swinging their front arms inwardly to the position shown in Fig. 3 and collapsing the tap, which latter can now be withdrawn from the screw-threaded article without mutilating the thread. The tap is thus automatically contracted upon completing its cut by the trip-rod *d'* coming in contact with an opposing abutment on the lathe. This trip-rod is preferably removably seated in a socket formed in the end of the expanding-rod D, as shown in Fig. 2, so that trip-rods of different lengths may be employed for cutting a longer or shorter screw-thread, as required. In order to again expand the tap-levers, the sleeve K is retracted by means of the hand-lever N. This releases the rear ends of the tap-levers and permits the compressed spring *g* to project the expanding-rod for spreading the front arms of the levers, as hereinbefore described.

Nut-blanks, collars, and similar articles which are open at both ends permit the use of a central trip-rod *d'* at the front end of the tap; but for tapping articles which are closed

at one end, such as screw-caps, such a front trip is not practicable. In tapping such closed articles I employ a trip-rod at the side of the tool and arrange a suitable stop or abutment on the lathe in the path of the same.

o represents the side trip-rod, which is secured at its inner end to the enlarged rear end of the expanding-rod D and extends laterally through longitudinal slots *o'* *o''*, formed in the body A and the contracting-sleeve K. Any suitable abutment may be arranged on the lathe in the path of this side trip-rod, so that the rod strikes the abutment and automatically retracts the expanding-rod when the tap has cut a thread of the desired length. I prefer to employ an ordinary tool-post as an abutment for the side trip.

The automatic action of my improved tap effects a considerable saving in time. It is durable in construction, and its simplicity enables it to be manufactured at comparatively small cost.

I claim as my invention—

1. In a screw-tap, the combination with a supporting-head, of tap-levers arranged lengthwise at the front end of said head and pivoted to the same between their ends, the front arms of said levers being provided with tapping-threads, an expanding-rod arranged to bear against the inner faces of said levers on the front side of their pivots, and a contracting-sleeve sliding on said head and engaging against the rear arms of said tap-levers, substantially as set forth.

2. The combination with a supporting-head and contractible tap sections or levers mounted on said head, of an expanding-rod movable lengthwise in said head and adapted to bear against the inner faces of said tap sections or levers, a spring arranged to force said expanding-rod forwardly, a trip-rod or projection connected with said expanding-rod and adapted to encounter a stop or abutment for retracting the expanding-rod, and a contracting device operating against said tap sections or levers, substantially as set forth.

3. The combination with a supporting-head and contractible tap sections or levers mounted on said head, of an expanding-rod movable lengthwise in said head and adapted to bear against the inner faces of said tap sections or levers, a spring arranged to force said expanding-rod forwardly, a trip rod or projection connected with said expanding-rod and adapted to encounter a stop or abutment for retracting the expanding-rod, a contracting-sleeve sliding on said head and bearing against said tap sections or levers, and a spring arranged to force said sleeve forwardly against said tap sections or levers, substantially as set forth.

4. The combination with a supporting-head, of tap-levers arranged lengthwise of the head and pivoted thereto between their ends, an expanding-rod arranged to slide lengthwise in the head and adapted to bear against the inner faces of said levers on the front sides

of their pivots, a spring arranged to force said expanding-rod forwardly, a projecting trip-rod connected with said expanding-rod, a contracting-sleeve sliding on said head and provided with a beveled face which bears against the rear arms of said tap-levers, and a spring arranged to force said sleeve against said levers, substantially as set forth.

5. The combination with a supporting-head and contractible tap sections or levers mounted on said head, of an expanding-rod movable lengthwise in said head and adapted to bear against the inner faces of said tap sections or levers, a spring arranged to force said expanding-rod forwardly, a contracting-sleeve sliding on said head, bearing against said tap-levers and provided with a transverse slot, a spring arranged to force said sleeve against said levers, and a hand-lever arranged in the slot of said sleeve and pivoted to said head, substantially as set forth.

6. The combination with a supporting-head and contractible sections or levers mounted on said head, of an expanding-rod movable lengthwise in said head and adapted to bear against the inner faces of said tap sections or levers, a spring arranged to force said ex-

panding-rod forwardly, a removable trip-rod arranged in the front end of said expanding-rod and projecting beyond said tap-levers, and a contracting device operating against said tap-levers, substantially as set forth.

7. The combination with a supporting-head provided at its front end with bifurcated radial lugs and at its rear end with a projecting collar, of tap-levers pivoted between their ends to said lugs, an expanding-rod sliding in an axial opening in said head and adapted to bear against the front arms of the tap-levers, a spring arranged in the axial opening of said head and bearing against the rear end of said expanding-rod, a trip-rod connected with said expanding-rod, a contracting-sleeve sliding on said head and bearing at its front end against the rear arms of said tap-levers, and a spring surrounding said head between the collar thereof and a shoulder of said sleeve, substantially as set forth.

Witness my hand this 28th day of June, 1899.

CLAES A. SVENSSON.

Witnesses:

CARL F. GEYER,
JNO. J. BONNER.